

# Stacker truck 1.2 ton

## BT staxio

*P-series*

SPE120XRD



# Pedestrian stacker double stacking

Specifications					SPE120XRD
Identification	1.1	Manufacturer			Toyota
	1.2	Model			SPE120XRD
	1.3	Drive			Electric
	1.4	Operator type			Stand on/Pedestrian
	1.5	Load capacity/rated load	Q	kg	1200/750
		Double stacking capacity	Q	kg	600+600
	1.6	Load center	c	mm	600
	1.8	Load distance, centre of support arm wheel to face of forks	x	mm	663
	1.9	Wheelbase	y	mm	1515
Weight	2.1	Service weight incl. battery		kg	1900
	2.3	Axle load, mast retracted without load, drive/fork wheel		kg	1240/660
	2.4	Axle load, mast extended with load, drive/fork wheel		kg	325/2775
	2.5	Axle load, mast retracted with load, drive/fork wheel		kg	1320/1780
Wheels	3.1	Drive/castor/fork wheel			Vulkollan®/ — /Vulkollan®
	3.2	Wheel size, front		mm	250
	3.3	Wheel size, rear		mm	140
	3.7	Track width, rear	b <sub>11</sub>	mm	810/995
Dimensions	4.2	Height, mast lowered	h <sub>1</sub>	mm	1797
	4.3	Free lift	h <sub>2</sub>	mm	132
	4.4	Lift height	h <sub>3</sub>	mm	2400
			h <sub>23</sub>	mm	2450
	4.5	Height, mast extended	h <sub>4</sub>	mm	2948
	4.6	Initial lift	h <sub>5</sub>	mm	300
	4.8	Stand height	h <sub>7</sub>	mm	190
	4.9	Height of tiller in drive position, min./max. highest setting lowest setting	h <sub>14</sub>	mm	1201/1413
			h <sub>14</sub>	mm	1101/1313
	4.10	Height of support arms	h <sub>8</sub>	mm	160
	4.15	Height, fork lowered	h <sub>13</sub>	mm	50
	4.19	Overall length, platform up/down	l <sub>1</sub>	mm	2280/2730
	4.20	Length to face of forks, platform up/down	l <sub>2</sub>	mm	1080/1505
	4.21	Overall width	b <sub>7</sub> /b <sub>2</sub>	mm	1085
	4.22	Fork dimensions	s/e/l	mm	35/75/1200
	4.25	Width over forks	b <sub>5</sub>	mm	Inner forks: 250 - 340, Outer forks: 510* - 750
	4.26	Distance between support arms	b <sub>4</sub>	mm	665/850
4.28	Reach distance	l <sub>4</sub>	mm	810	
4.31	Ground clearance, below mast	m <sub>1</sub>	mm	30	
4.32	Ground clearance, center of wheelbase	m <sub>2</sub>	mm	40	
4.33	Aisle width for pallets 1000x1200 crossways, platform up/down	A <sub>st</sub>	mm	2648/3098	
4.34	Aisle width for pallets 800x1200 lengthways, platform up/down	A <sub>st</sub>	mm	2630/3080	
4.35	Turning radius, platform up/down	W <sub>a</sub>	mm	1760/2210	
4.37	Length across support arms, platform up/down	l <sub>7</sub>	mm	1830	
Performance data	5.1	Travel speed, with/without load 6 km/h version 8 km/h version	km/h	6,0/6,0	
			km/h	7,0/8,0	
	5.2	Lift speed, with/without load	m/s	0,20/0,36	
	5.3	Lowering speed, with/without load	m/s	0,45/0,45	
	5.4	Reach speed, with/without load	m/s	0,15/0,15	
	5.8	Max. gradeability, with/without load <sup>1)</sup>	%	8/10	
5.9	Acceleration time (over 10 m)	s	5,8		
5.10	Service brake		Electromagnetic		
Electric motor	6.1	Drive motor rating (S2 60min) 6 km/h version 8 km/h version	kW	1,8	
			kW	1,8	
	6.2	Lift motor rating (S3 15%)	kW	3	
	6.4	Battery voltage, nominal capacity K <sub>s</sub>	V/Ah	24/300	
	6.5	Battery weight	kg	195 - 270	
	6.6	Energy consumption acc to VDI cycle	kWh/h	1,1	
Others	8.1	Type of drive control		Variable AC	
	8.4	Sound level at the driver's ear according to EN 12 053	dB (A)	59	

1) Measured according to company standard.

\* = Depending on inner forks position.

Data is based on standard truck and small battery.

All data are based on table configuration. Other configurations may give other values.

Truck performance and dimensions are nominal and subject to tolerances.

Toyota Material Handling Manufacturing Sweden AB products and specifications are subject to change without notice.

# Mast dimensions

SPE120XRD			Duplex Tele Panoramic View	
$h_{23}$	Lift height ( $h_{13}+h_3$ )	mm	2450	2750
$h_3$	Lift	mm	2400	2700
$h_1$	Height, mast lowered	mm	1797	1947
$h_2$	Free lift	mm	132	132
$h_4$	Height, mast extended	mm	2948	3248
$h_5$	Initial lift	mm	300	300

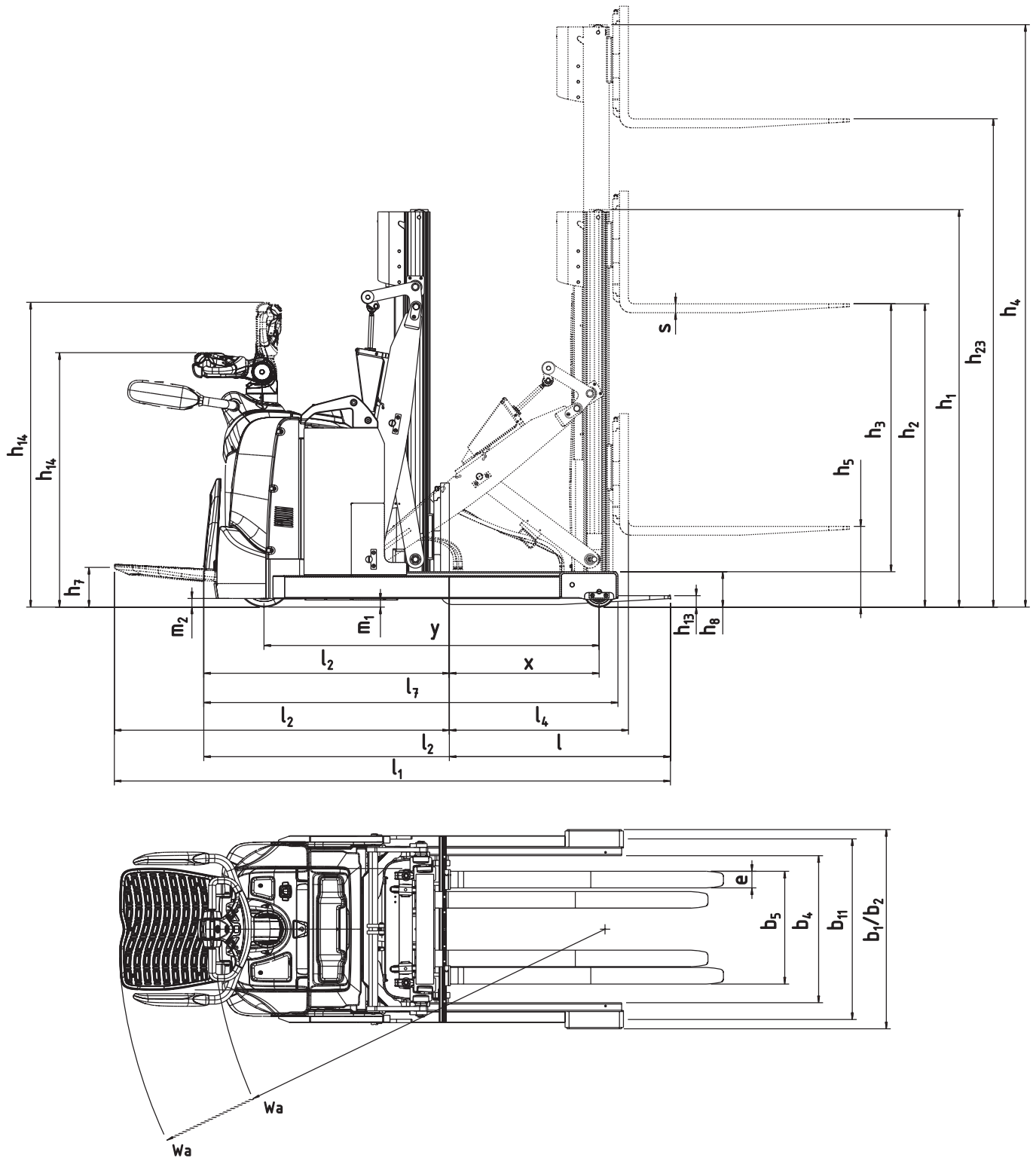

---

## Truck features:

- 180°+ Power/Electronic steering
- Optimised Truck Performance
- Reach mast with Pantograph fork mechanism
- Double pallet handling
- Adjustable fork width
- Sensi-lift
- Height adjustable tiller arm
- One-touch foldable gates
- Click-2-Creep
- Electronic fingertip controls for all functions
- Access control
- Driver-adapted programmable performance
- Easy access for maintenance
- I\_Site (option)
- Li-Ion battery (option)
- Coldstore version (option)

