

Pedestrian stacker truck 2.0 ton



BT staxio

P-series

SPE200D

SPE200DN



Pedestrian stacker double stacking

Specifications				SPE200D	SPE200DN	
Identification	1.1	Manufacturer		Toyota	Toyota	
	1.2	Model		SPE200D	SPE200DN	
	1.3	Drive		Electric	Electric	
	1.4	Operator type		Stand on/pedestrian	Stand on/pedestrian	
	1.5	Load capacity/rated load	Q	kg	1000	1000
		Double stacking capacity – fork/support arm capacity	Q	kg	1000 + 1000	800 + 1200
	1.6	Load center	c	mm	600	600
	1.8	Load distance, centre of support arm wheel to face of forks raised support arms lowered support arms	x	mm	961	849
			x	mm	992	880
1.9	Wheelbase raised support arms lowered support arms	y	mm	1708	1608	
		y	mm	1739	1639	
Weight	2.1	Service weight incl. battery		kg	1243	
	2.2	Axle load, with load, drive/castor/fork wheel		kg	880/495/1868	
	2.3	Axle load, without load, drive/castor/fork wheel		kg	440/461/342	
Wheels	3.1	Drive/castor/fork wheel			Vulkollan®/Vulkollan®/Vulkollan®	
	3.2	Wheel size, front		mm	Ø 230	
	3.3	Wheel size, rear		mm	Ø 85	
	3.4	Additional wheel size		mm	Ø 125	
	3.5	Wheels, number front/rear (x = driven wheels)				1x+2/2 or 4
	3.6	Track width, front	b ₁₀	mm	560	498
	3.7	Track width, rear	b ₁₁	mm	390	390
Dimensions	4.2	Height, mast lowered	h ₁	mm	1785	1540
	4.3	Free lift	h ₂	mm	1356	172
	4.4	Lift height	h ₃	mm	2410	2010
			h ₂₃	mm	2500	2100
	4.5	Height, mast extended	h ₄	mm	3018	2525
	4.6	Initial Lift	h ₅	mm	120	120
	4.8	Stand height	h ₇	mm	190	190
	4.9	Height of tiller in drive position, min./max. highest setting lowest setting	h ₁₄	mm	1201/1413	1201/1413
			h ₁₄	mm	1101/1313	1101/1313
	4.15	Height, fork lowered	h ₁₃	mm	90	90
	4.19	Overall length platform up platform down	l	mm	2165	2127
			l	mm	2615	2577
	4.20	Length to face of forks platform up platform down	l ₂	mm	1015	977
			l ₂	mm	1465	1427
	4.21	Overall width	b ₁ /b ₂	mm	790/—	748/—
	4.22	Fork dimensions	s/e/l	mm	70/180/1200	70/180/1200
	4.25	Width over forks	b ₅	mm	570	570
4.32	Ground clearance, center of wheelbase	m ₂	mm	19,5	19,5	
4.33	Aisle width for pallets 1000x1200 crossways platform up platform down	A _{st}	mm	2783	2735	
		A _{st}	mm	3252	3128	
4.34	Aisle width for pallets 800x1200 lengthways platform up platform down	A _{st}	mm	2620	2530	
		A _{st}	mm	3089	2965	
4.35	Turning radius platform up platform down	W _a	mm	1954	1864	
		W _a	mm	2423	2299	
Performance data	5.1	Travel speed, with/without load		km/h	9,0/10,0	
	5.2	Lift speed, with/without load		m/s	0,18/0,33	
	5.3	Lowering speed, with/without load		m/s	0,45/0,45	
	5.8	Max. gradeability, with/without load ¹⁾		%	8/12	
	5.9	Acceleration time (over 10 m)		s	5,6	
	5.10	Service brake				Electromagnetic
Electric motor	6.1	Drive motor rating (S2 60min)		kW	2,5	
	6.2	Lift motor rating (S3 15%)		kW	3,0	
	6.4	Battery voltage, nominal capacity K _s		V/Ah	24/300	
	6.5	Battery weight		kg	195-270	
	6.6	Energy consumption acc to VDI cycle		kWh/h	0,88	
						0,75
Others	8.1	Type of drive control			Variable AC	
	8.4	Sound level at the driver's ear according to EN 12 053		dB (A)	65	

1) Measured according to company standard.

Data is based on standard truck and small battery.

All data are based on table configuration. Other configurations may give other values.

Truck performance and dimensions are nominal and subject to tolerances.

Toyota Material Handling Manufacturing Sweden AB products and specifications are subject to change without notice.

Battery dependent dimensions

Dimensions		Battery		SPE200D				SPE200DN			
				Lift out		Sideways		Lift out		Sideways	
				S	L*	S	L*	S	M	S	M
1.9	Wheelbase										
	raised support arms	y	mm	1708	1805	1708	1805	1608	1653	1608	1653
	lowered support arms	y	mm	1739	1836	1739	1836	1639	1687	1639	1687
4.19	Overall length										
	platform up	l_1	mm	2165	2262	2165	2262	2127	2175	2127	2175
	platform down	l_1	mm	2615	2712	2615	2712	2577	2625	2577	2625
4.20	Length to face of forks										
	platform up	l_2	mm	1015	1112	1015	1112	977	1025	977	1025
	platform down	l_2	mm	1465	1562	1465	1562	1427	1475	1427	1475
4.33	Aisle width for pallets 1000x1200 crossways										
	platform up	A_{st}	mm	2783	2880	2783	2880	2735	2783	2735	2783
	platform down	A_{st}	mm	3252	3349	3252	3349	3128	3177	3128	3177
4.34	Aisle width for pallets 800x1200 lengthways										
	platform up	A_{st}	mm	2620	2717	2620	2717	2530	2578	2530	2578
	platform down	A_{st}	mm	3089	3186	3089	3186	2965	3014	2965	3014
4.35	Turning radius										
	platform up	W_a	mm	1954	2051	1954	2051	1864	1912	1864	1912
	platform down	W_a	mm	2423	2520	2423	2520	2299	2348	2299	2348
6.4	Battery voltage, nominal capacity K_s		V/Ah	24/300	24/500	24/300	24/500	24/300	24/400	24/300	24/400
6.5	Battery weight, min.—max.		kg	195-310	345-405	195-310	345-405	195-310	345-405	195-310	345-405

* DIN battery will give same truck dimensions as for the large battery

Mast dimensions

Mast			Duplex Tele Panoramic View				Duplex HiLo	
SPE200D/DN	h_{23}	Lift height ($h_{13}+h_3$)	mm	1600	1750	1900	2100	2500
	h_3	Lift	mm	1510	1660	1810	2010	2410
	h_1	Height, mast lowered	mm	1335	1410	1475	1585	1785
	h_4	Height, mast extended	mm	2118	2268	2408	2618	3018
	h_2	Free lift	mm	172	172	172	172	1356

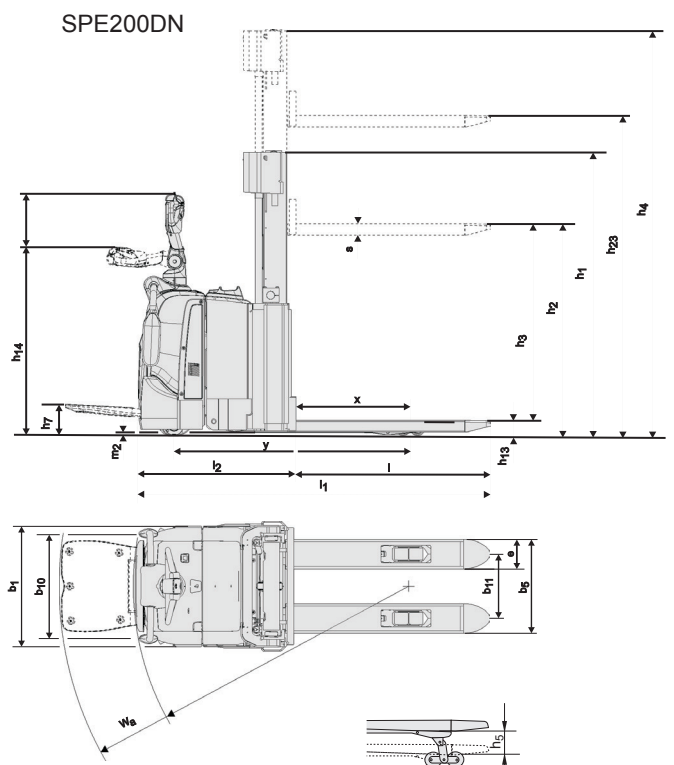
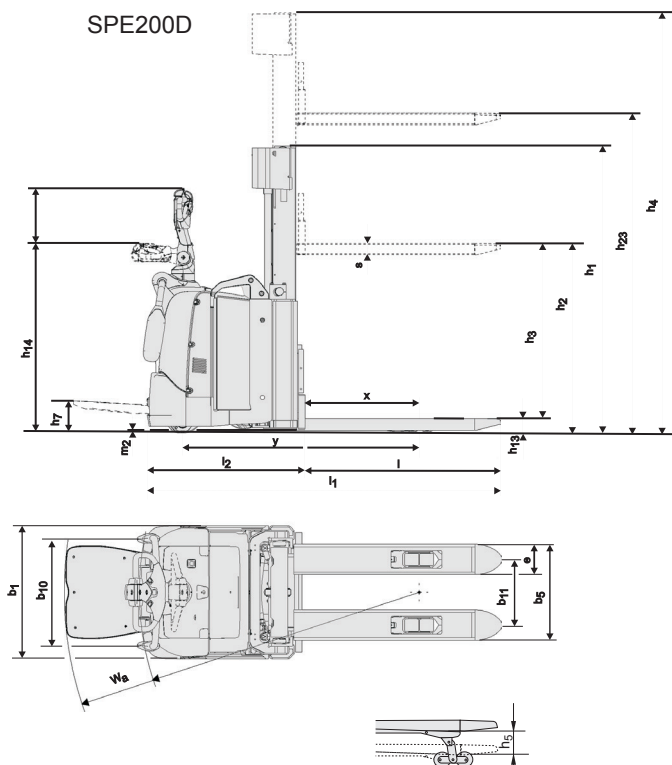

Truck features:

- BT Powertrak traction system
- Optimized Truck Performance
- Fingertip controls
- Electronic braking system
- Electronic speed control
- Operator safety
- Storage compartments
- Automatic switch-off
- Programmable performance
- Easy access for maintenance
- Sensilift
- Toyota I_site: truck fleet management system (option)
- Hydraulic oil for low temperatures (option)

